



**542 3<sup>Rd</sup> Street, Lake Elsinore, CA 92530**

**TEL: 951-245-8669, FAX: 951-245-5481**



**Chevy Camaro 82-92**

**Pontiac Firebird/Trans AM 82-92**

**U.S. PATENTS**

**#6,808,223; #6,845,547; #7,140,075; #7,059,655**

**PATENTS AGGRESSIVELY ENFORCED!**





**PLEASE CAREFULLY READ ALL INSTRUCTIONS BEFORE  
ATTEMPTING TO INSTALL THIS PRODUCT.**

**FOR QUESTIONS PLEASE  
CONTACT US AT (951) 245-8669**

**THIS KIT INCLUDES:**

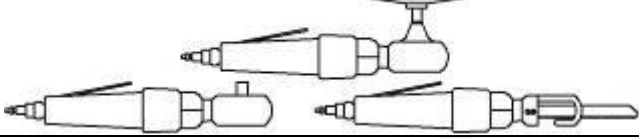
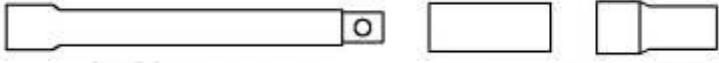
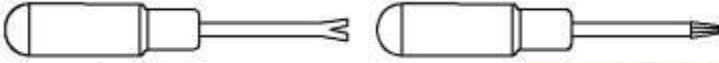
- 2 SHOULDER BOLTS WITH WASHERS
- 2 PINS
- 2 SHOCKS
- 4 CHASSIS SPACERS
- RIGHT AND LEFT HINGE ASSEMBLY
- HARDWARE KIT

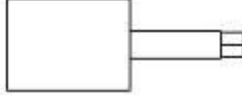
**TOOLS REQUIRED FOR INSTALLATION:**

	<ul style="list-style-type: none"> <li>➤ AIR RACHET, GRINDER AND CUTTER.</li> </ul>
	<ul style="list-style-type: none"> <li>➤ 7MM, 8MM, 10MM, 11MM, 13MM, SOCKETS AND EXTENSION.</li> </ul>
	<ul style="list-style-type: none"> <li>➤ FORK AND PHILLIP'S SCREW DRIVERS</li> </ul>
	<ul style="list-style-type: none"> <li>➤ SPACERS FOR THE DOOR GAP.</li> </ul>
	<ul style="list-style-type: none"> <li>➤ 3/16 ALLEN WRENCH</li> </ul>
	<ul style="list-style-type: none"> <li>➤ 1/4 TORX BIT</li> </ul>
	<ul style="list-style-type: none"> <li>➤ 9/16 WRENCH</li> </ul>
	<ul style="list-style-type: none"> <li>➤ LOCKTITE RED</li> </ul>

**OTHER TOOLS MAY BE NEEDED DEPENDING ON YOUR VEHICLE.**

**“Installers with experience recommended”**

**(Note: The pictures on the manual are for reference only they may not match your vehicle.)**



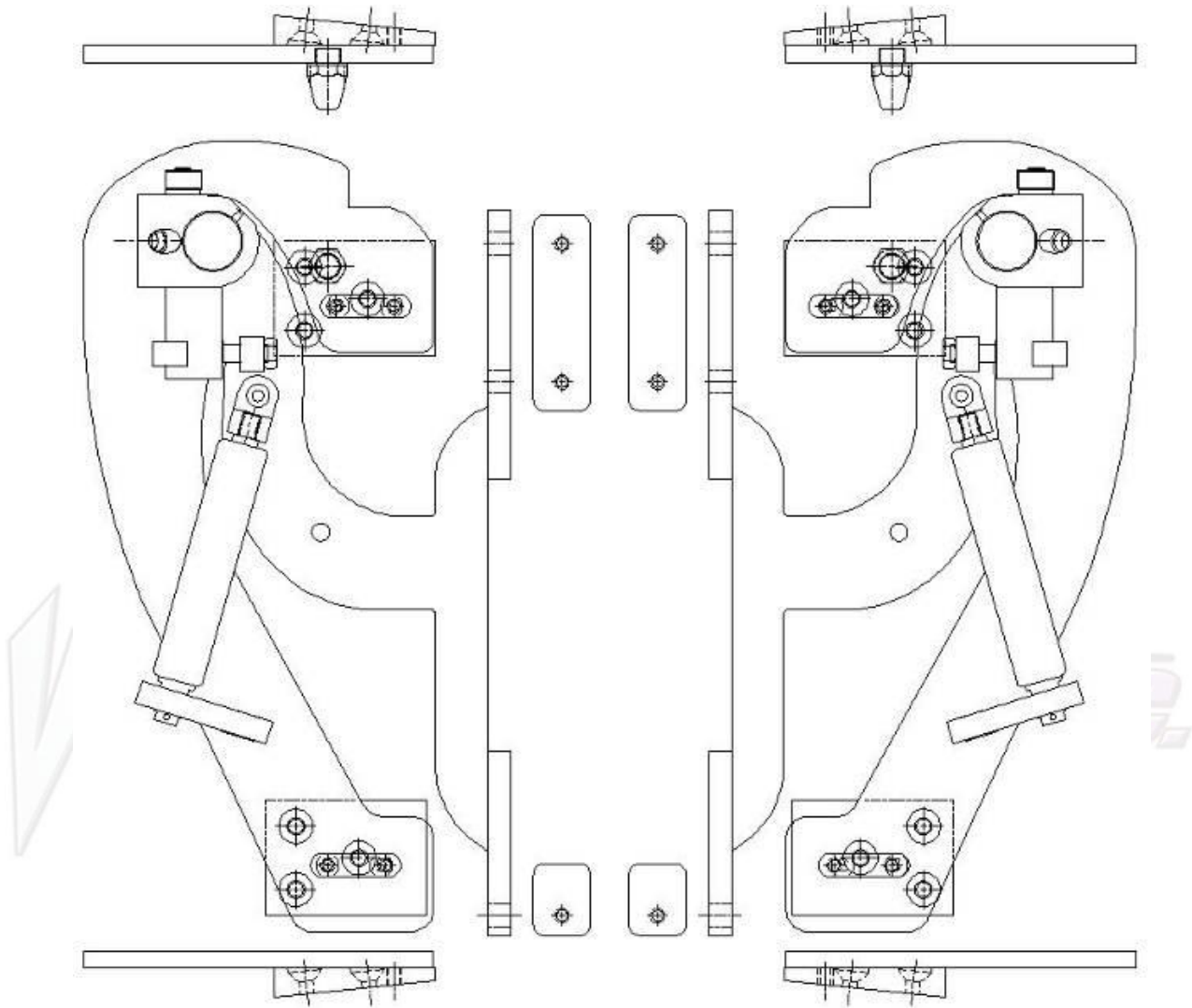

Disconnect the battery.

You will need to disconnect the door wire harness  
 Remove the door panel and disconnect all electrical connections.

Remove fender:

Remove all screws and fasteners from the wheel well, and the bolts securing the fender to the bumper.

Open the hood and remove all fasteners from the top of the fender.

Remove the bolts securing the fender to the apron by the door.

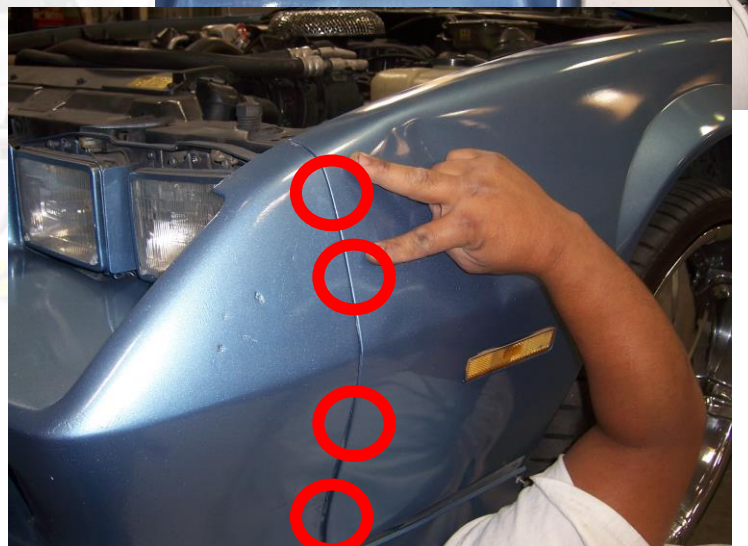
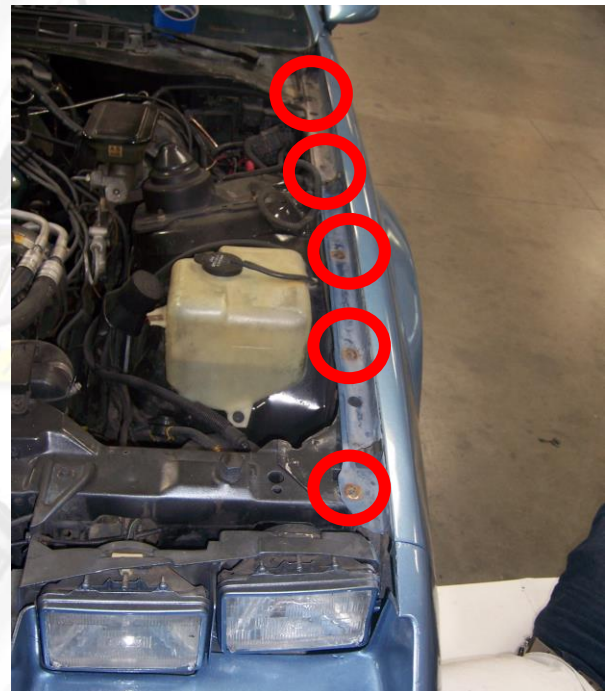



After removing the fender mark the factory location of your door. Make sure to mark the horizontal and vertical location of the door also measure the distance from the apron to the edge of the front door by the bottom and top hinge.



Unbolt the hinges from the body and remove the doors from the car.

After removing the door from the car install the spacers on the top and bottom hinge as shown

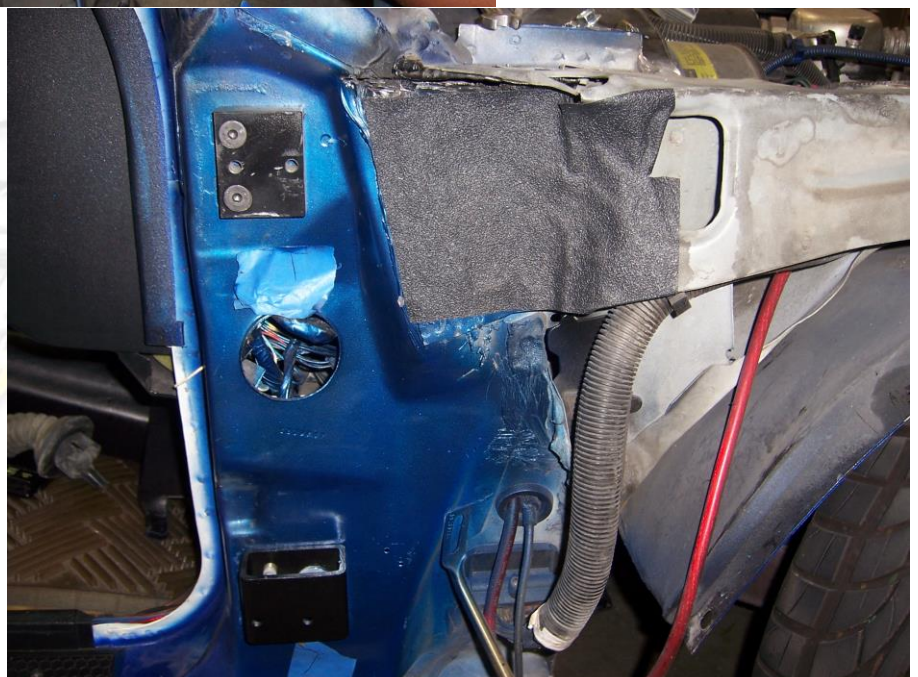



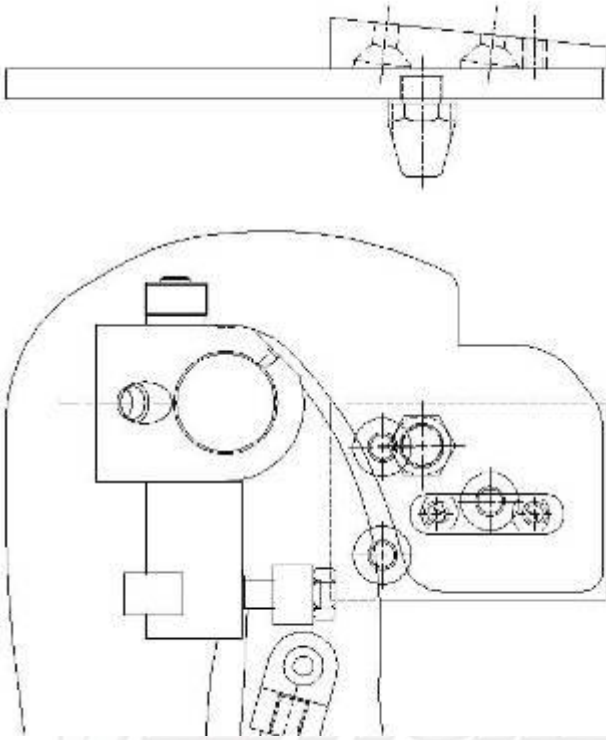

Top of hinge

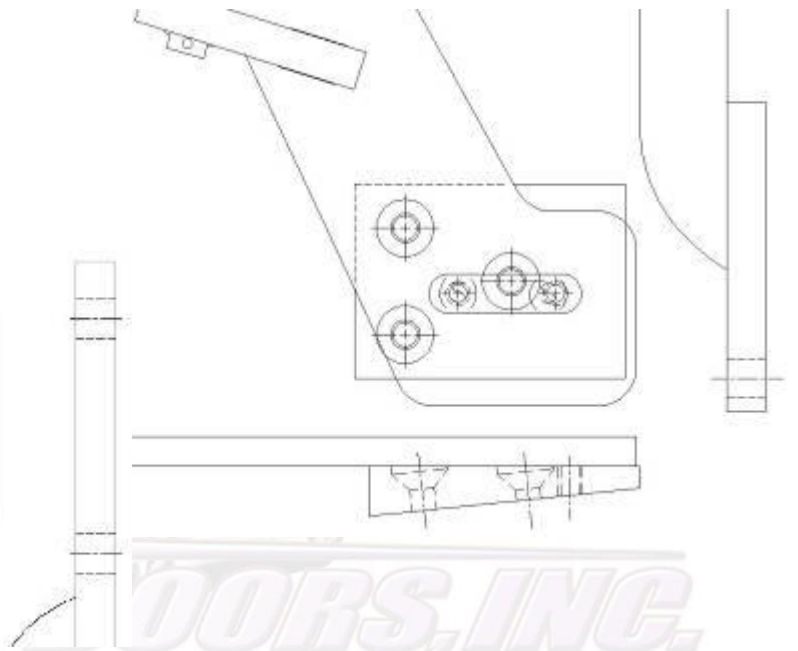

Bottom of hinge

Modify the apron as shown.

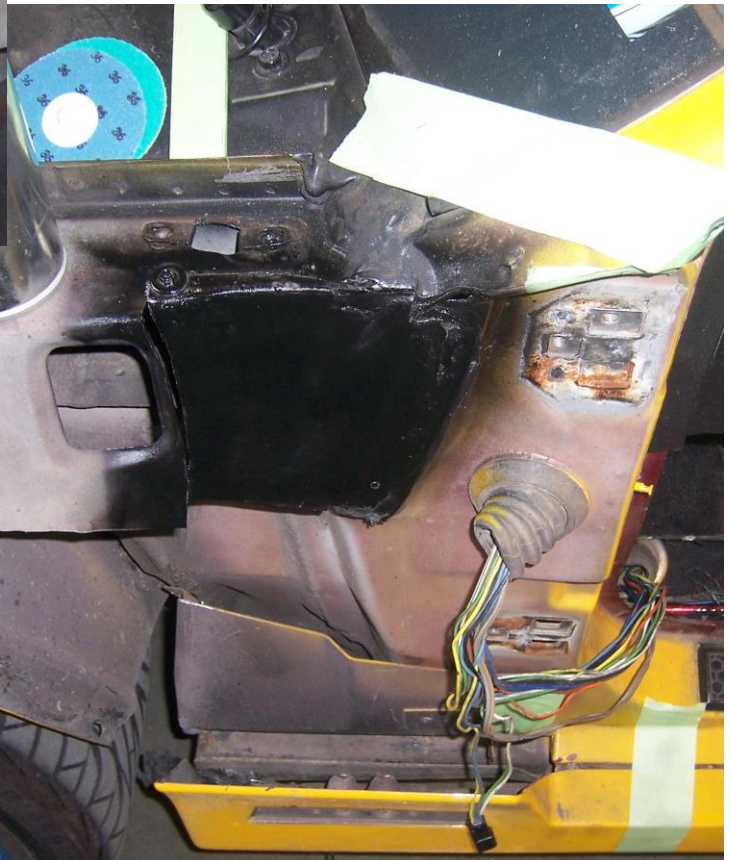



Remove the door panel and cut the factory hinges off of the car as shown.



After trimming off the “wings” from the factory hinges align your templates and secure them with tape. You will need to drill and tap new holes in order to secure the VDI hinge to the door.

Install the new VDI hinge on the door as shown and replace the door to the body.

Make sure to follow the factory location marks you made earlier.





Use 2" painters tape to secure the door to the body.



After installing the bolts that secure the new VDI hinge to the chassis spacers, cut the factory wire loom in half and use the provided wire loom to protect the exposed wires.



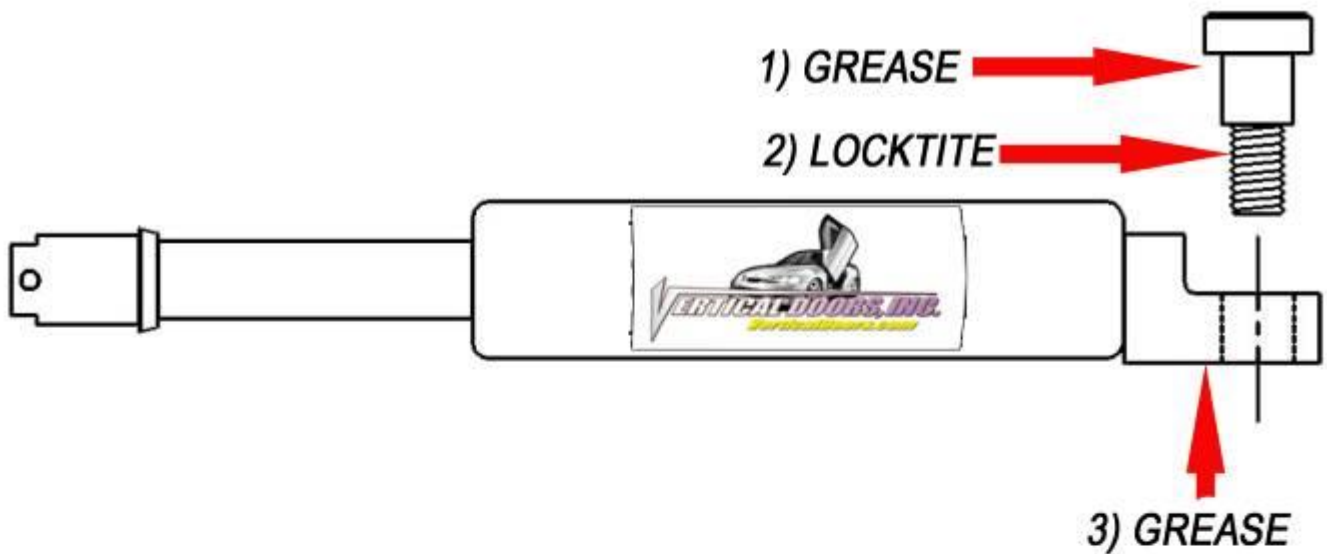

**\*IMPORTANT STEP: DO NOT SKIP THIS STEP. THIS STEP IS CRUCIAL IN YOUR INSTALLATION PROCESS, IF THIS STEP IS NOT COMPLETED WHEN INSTALLING THE VERTICAL DOOR KIT; ALL WARRANTIES ARE VOIDED, AND MAY CAUSE FUTURE PROBLEMS WITH YOUR VERTICAL DOOR SYSTEM.**

**1ST, make sure you put grease on the body of shoulder bolt where the arrow is pointing.**

**2ND, make sure you put red Loctite, where the arrow is pointing, on thread of shoulder bolt.**

**3RD, make sure you put grease on the bottom side of the shock end.**

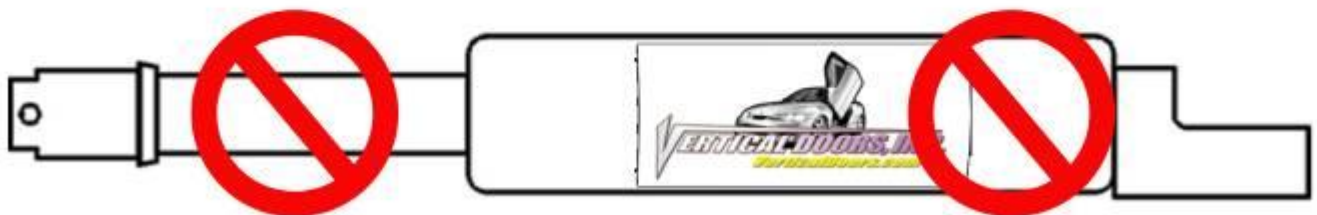

**WARNING! THE USE OF ANY TYPE PLYERS, PAINT OR FOREIGN MATERIALS ON THE SHOCK'S BODY OR SHAFT WILL VOID THE WARRANTY.**

**VERTICAL DOORS, INC.**  
[VerticalDoors.com](http://VerticalDoors.com)



Once hinge is locked in place, break nut #1 then turn Allen set screw #2 on fig until it hits the block then open the door and continue to adjust until the door matches with the striker, open and close door making sure it closes like factory.

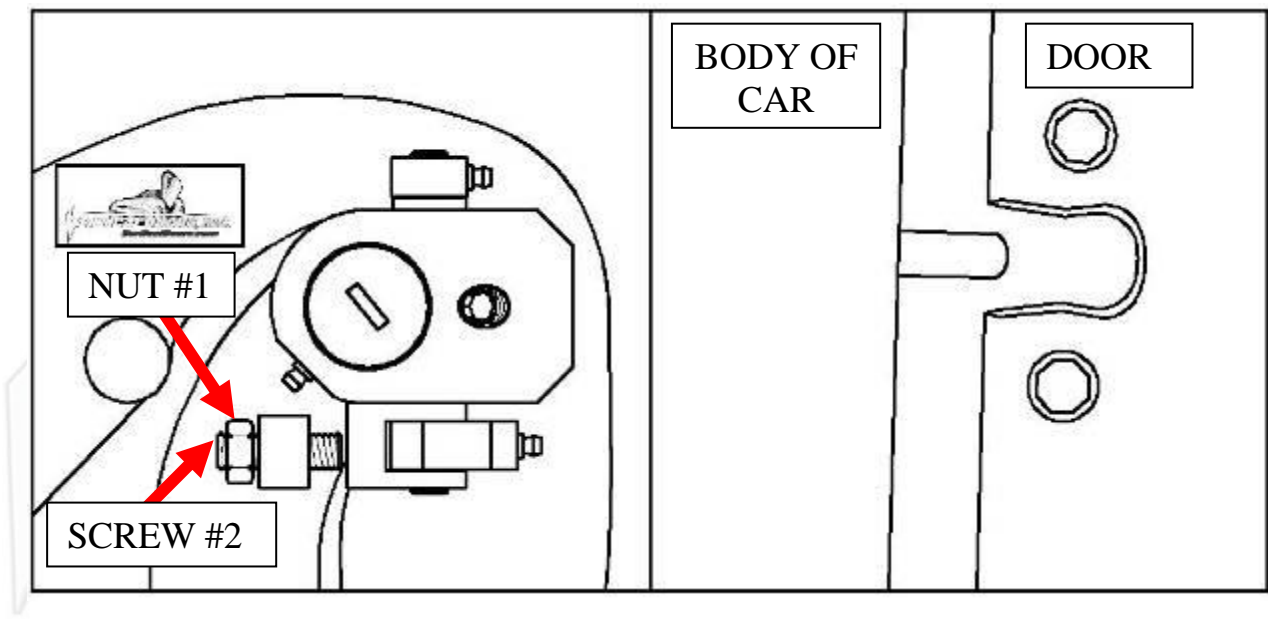

*Hint\**(leave #1 nut loose until shock is installed Allen set screw will have to be re-adjusted after shock is installed).

Install the shock.

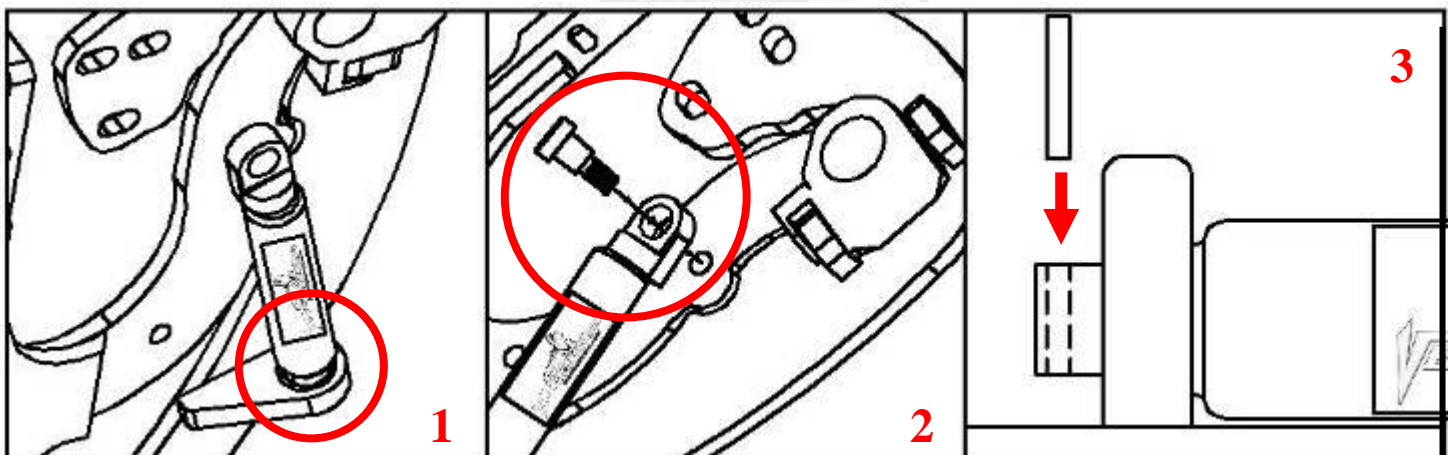

*Hint\** (You will need a helper to raise the door). (Slip the spherical rod mount into the spherical ball bearing (1). Using a 1/4 Allen wrench, tighten the screw into the swing arm (2). After the shock is installed secure it by installing the pin in the bottom shock end (3).

**VERTICAL DOORS, INC.**  
[VerticalDoors.com](http://VerticalDoors.com)

After shock is installed re-install door panel and lift the door. Adjust door opening screw #3 clockwise until distance between nub and swing arm is enough so that the swing arm moves up and down freely.

*Hint\* (Fine tune the Allen Adjustment screw (#2) to realigned striker with door. After the door is align test door by opening and closing, lifting and lowering door several times.*

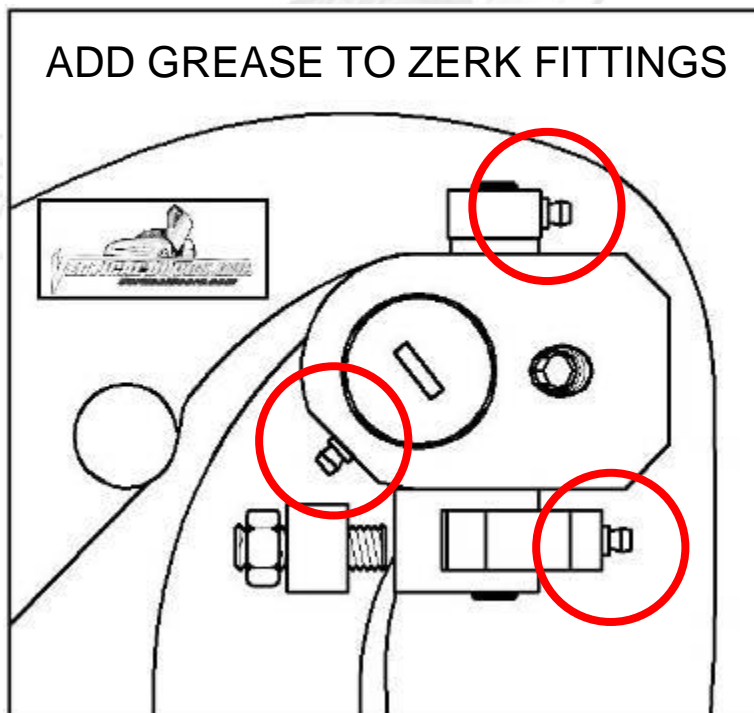
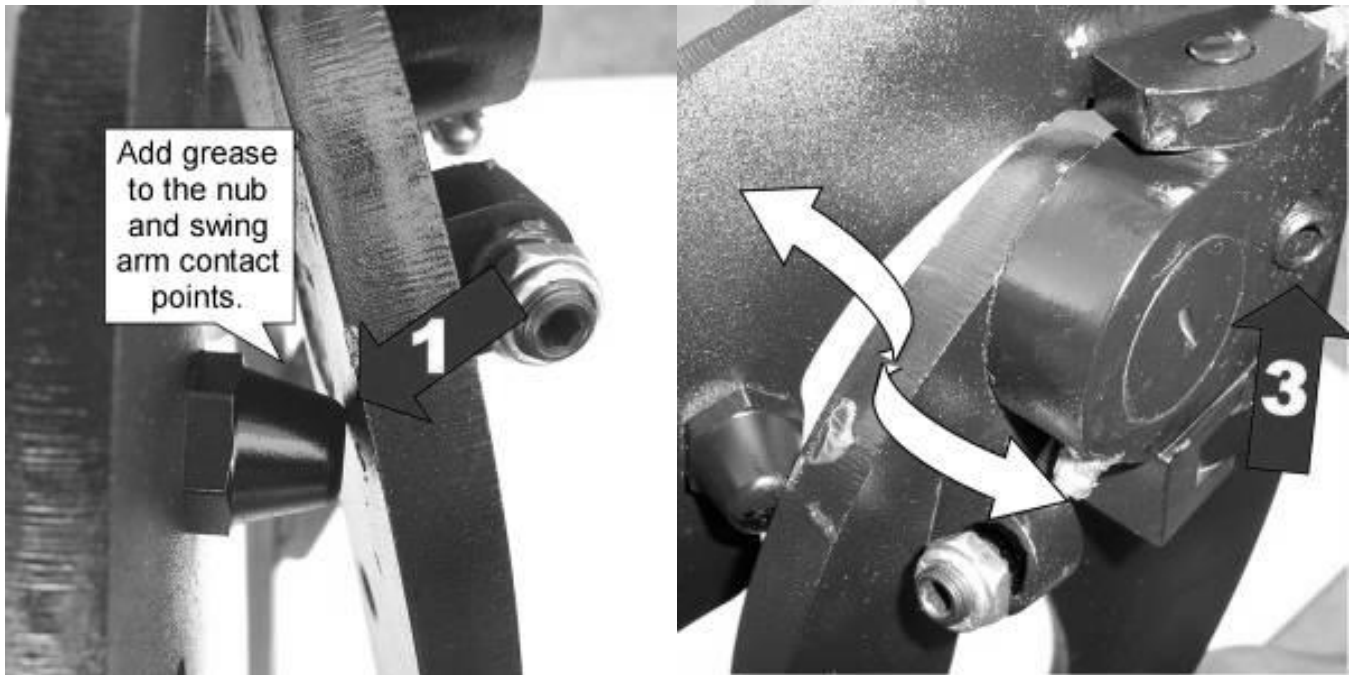

**Note: Do not install fender until the adjustment of the door is accurate, and the set screw is tightly secure. Also make sure everything is tight, adjustment is set and everything is Locktite.**



The hinge should look like the picture below when you are done.



Cut the inner lip of your fender to make room for the new Vertical Doors hinge. Note: After you have cut the fender use a sander or grinder and make sure the surface is completely flat and smooth.

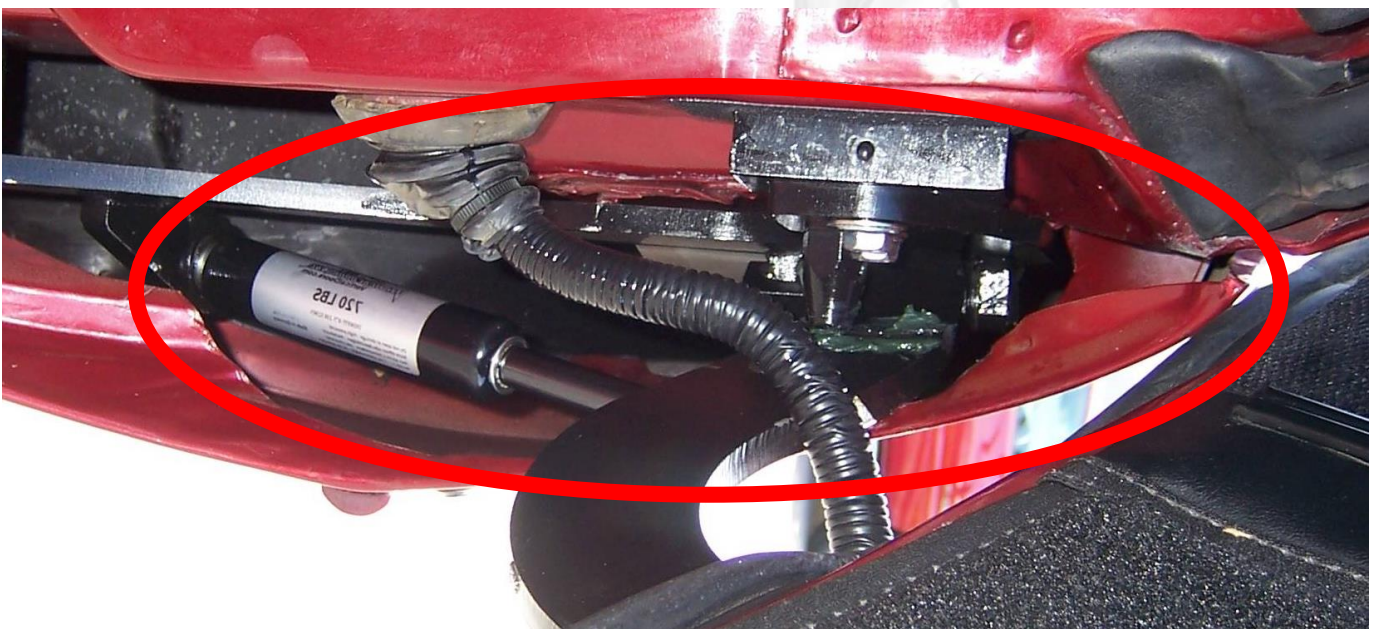

Close the door and replace the fender.

*Hint\*(Make sure the electrical wires don't get pinched enough to damage wires)*

Follow the same steps for the other side.

**Thank you for your purchase of the  
*VERTICAL DOORS INC. SYSTEM***

*Simply Uplifting*



**NOTE:**

Vertical Doors Inc. assumes no responsibility for any damages caused by improper installation